

**IN THE UNITED STATES DISTRICT COURT
FOR THE NORTHERN DISTRICT OF ILLINOIS
EASTERN DIVISION**

GS HOLISTIC, LLC,

Plaintiff,

v.

THE PARTNERSHIPS and
UNINCORPORATED ASSOCIATIONS
IDENTIFIED ON SCHEDULE “A,”

Defendants.

Case No. 22-cv-02781

COMPLAINT

Plaintiff GS Holistic, LLC (“Plaintiff”) hereby brings the present action against the Partnerships and Unincorporated Associations identified on Schedule A attached hereto (collectively, “Defendants”) and alleges as follows:

I. JURISDICTION AND VENUE

1. This Court has original subject matter jurisdiction over the claims in this action pursuant to the provisions of the Patent Act, 35 U.S.C. § 1, *et seq.*, 28 U.S.C. § 1338(a)-(b) and 28 U.S.C. § 1331.

2. Venue is proper in this Court pursuant to 28 U.S.C. § 1391, and this Court may properly exercise personal jurisdiction over Defendants since each of the Defendants directly targets business activities toward consumers in the United States, including Illinois, through at least the fully interactive, e-commerce stores¹ operating under the seller aliases identified in Schedule A attached hereto (the “Seller Aliases”). Specifically, Defendants have targeted sales to Illinois residents by setting up and operating e-commerce stores that target United States

¹ The e-commerce store urls are listed on Schedule A hereto under the Online Marketplaces.

consumers using one or more Seller Aliases, offer shipping to the United States, including Illinois, accept payment in U.S. dollars and, on information and belief, have sold products featuring Plaintiff's patented design to residents of Illinois. Each of the Defendants is committing tortious acts in Illinois, is engaging in interstate commerce, and has wrongfully caused Plaintiff substantial injury in the State of Illinois.

II. INTRODUCTION

3. This action has been filed by Plaintiff to combat e-commerce store operators who trade upon Plaintiff's reputation and goodwill by making, using, offering for sale, selling and/or importing into the United States for subsequent sale or use the same unauthorized and unlicensed product, namely the hookah shown in Exhibit 1, that infringes Plaintiff's patented design, U.S. Patent No. D943,817 (the "Infringing Products"). Defendants create e-commerce stores operating under one or more Seller Aliases that are making, using, offering for sale, selling, and/or importing into the United States for subsequent sale or use Infringing Products to unknowing consumers. E-commerce stores operating under the Seller Aliases share unique identifiers establishing a logical relationship between them, suggesting that Defendants' operation arises out of the same transaction, occurrence, or series of transactions or occurrences. Defendants attempt to avoid and mitigate liability by operating under one or more Seller Aliases to conceal both their identities and the full scope and interworking of their operation. Plaintiff has filed this action to combat Defendants' infringement of its patented design, as well as to protect unknowing consumers from purchasing Infringing Products over the Internet. Plaintiff has been and continues to be irreparably damaged from the loss of its lawful patent rights to exclude others from making, using, selling, offering for sale, and importing its patented design as a result of Defendants' actions and seeks injunctive and monetary relief.

III. THE PARTIES

Plaintiff GS Holistic, LLC

4. Plaintiff GS Holistic, LLC is a limited liability company organized and existing under the laws of the State of Delaware with a principal place of business at 7162 Beverly Boulevard, #207, Los Angeles, California 90036.

5. Since 2012, Plaintiff has been engaged in the design, distribution, and sale of user-friendly portable vaporizers, hookahs, gravity infusers, and related accessories (collectively, the “GS Products”). Plaintiff engineers the most advanced, user-friendly portable vaporizers, hookahs, and gravity infusers in the world. GS Products have become enormously popular and even iconic, driven by Plaintiff’s arduous quality standards and innovative design. Among the purchasing public, genuine GS Products are instantly recognizable as such. In the United States and around the world, Plaintiff’s brand has come to symbolize high quality, and GS Products are among the most recognizable gravity infusers and hookahs in the world.

6. GS Products are distributed and sold to consumers through approved dealers throughout the United States, including in Illinois, and via the gpen.com and stundenglass.com websites.

7. GS Products are known for their distinctive patented designs. These designs are broadly recognized by consumers. Hookahs fashioned after these designs are associated with the quality and innovation that the public has come to expect from GS Products. Plaintiff uses these designs in connection with its GS Products, including, but not limited to, the following patented design, herein referred to as the “GS Design.”

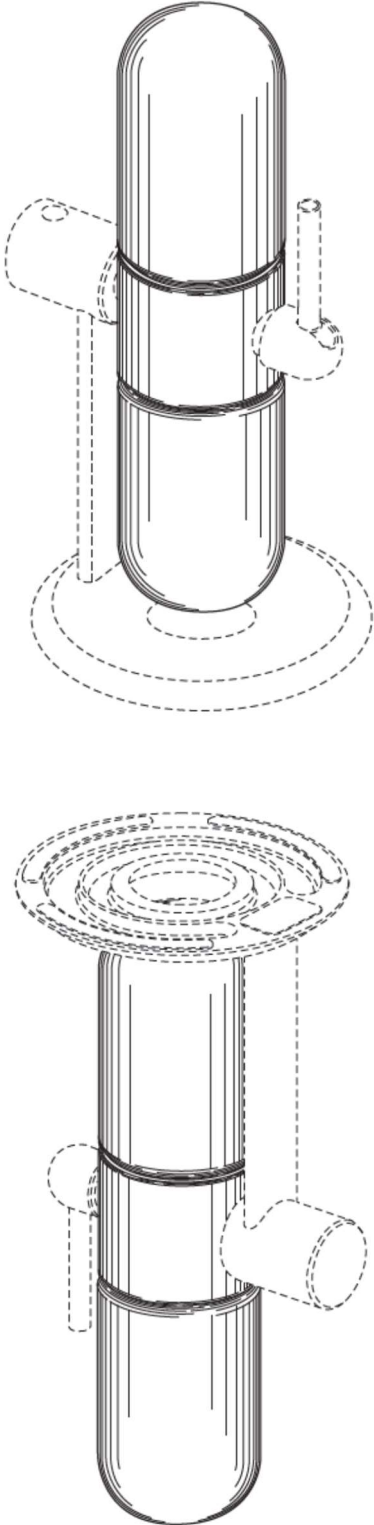
Patent Number	Claim	Issue Date
D943,817		February 15, 2022

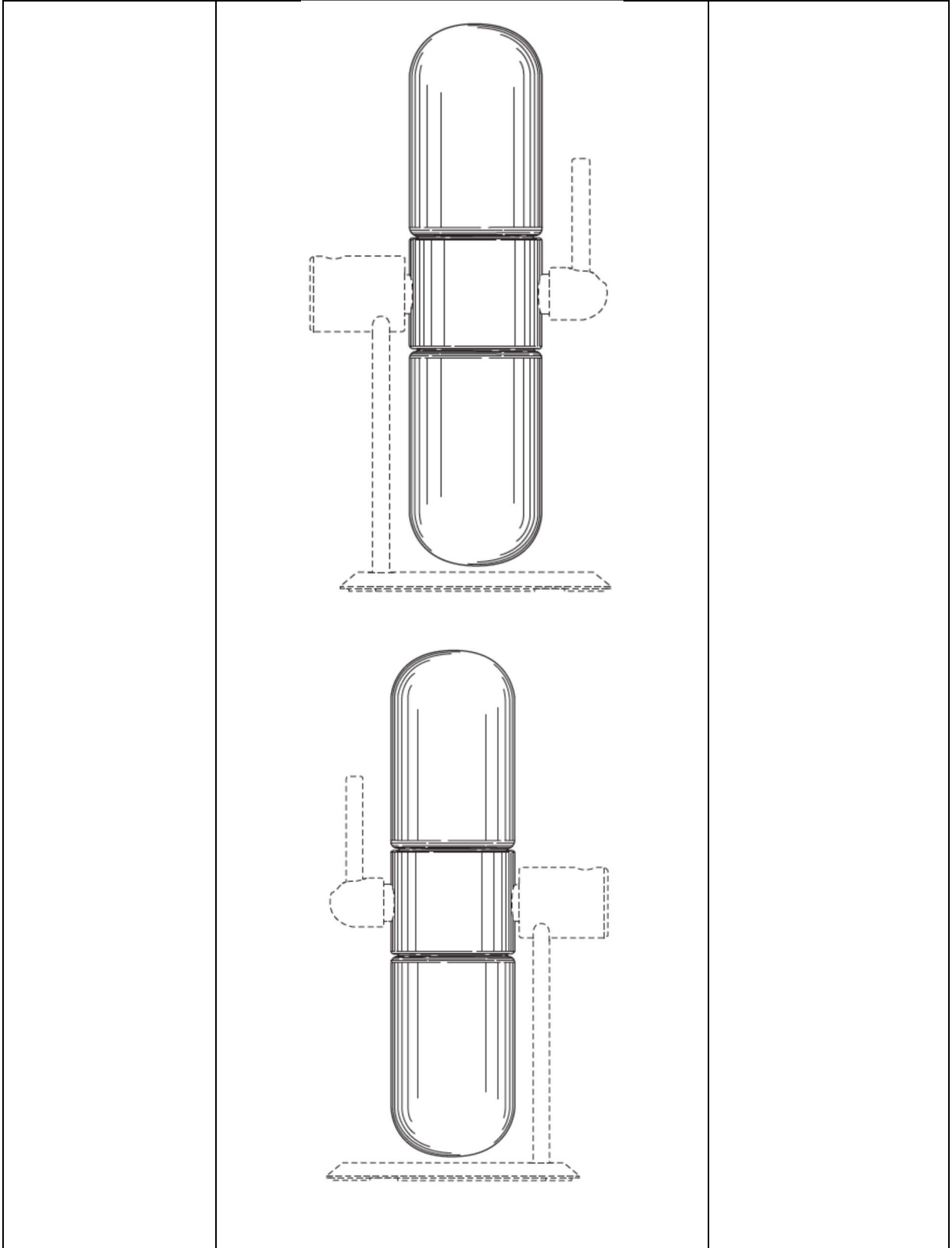

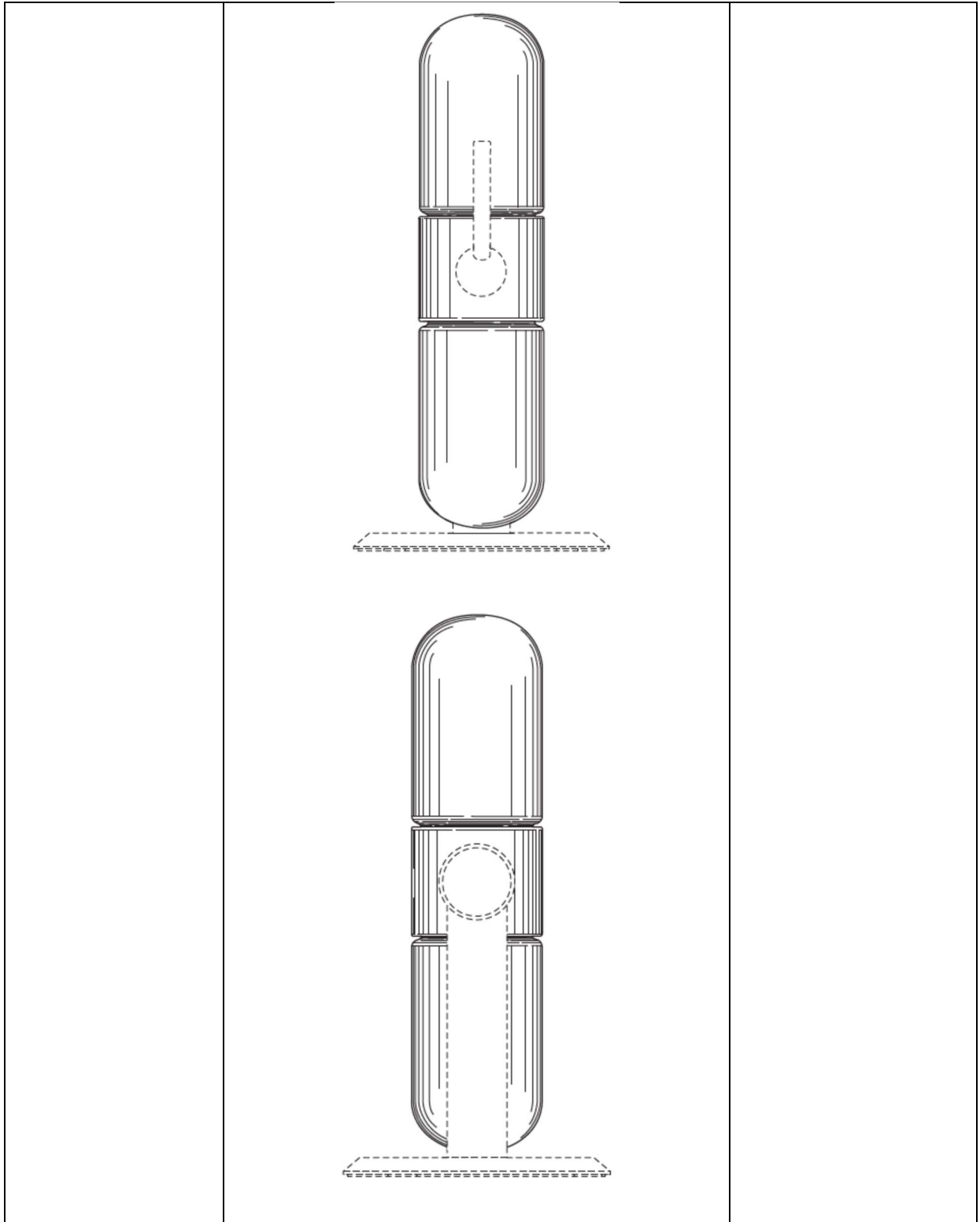

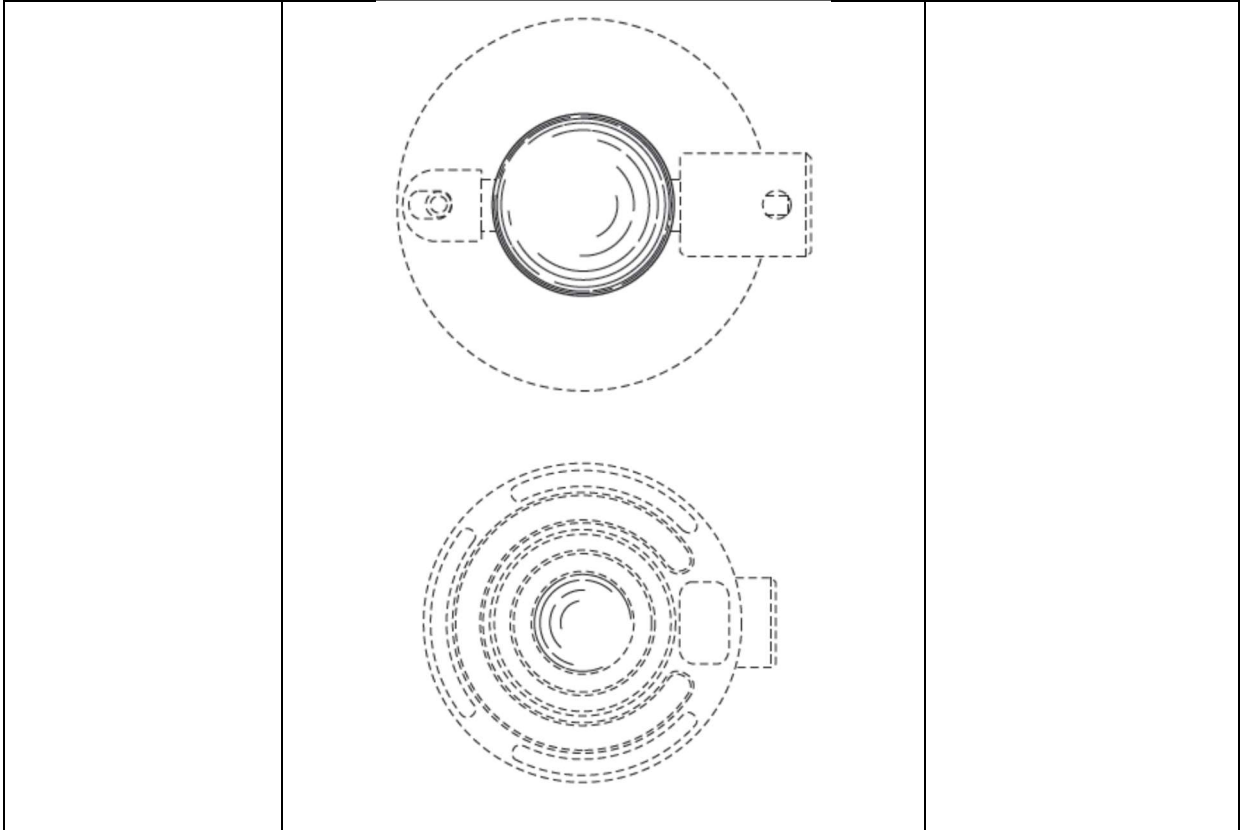

8. Plaintiff is the lawful assignee of all right, title, and interest in and to the GS Design. The patent for the GS Design was lawfully issued on February 15, 2022, with named inventors Christiaan Rule, David Vuong, Christopher Folkerts, Gabriel Alvarez, Tracey Huston, and Michael Trzeczieski. Attached hereto as **Exhibit 2** is a true and correct copy of the United States Patent for the GS Design.

The Defendants

9. Defendants are individuals and business entities of unknown makeup who own and/or operate one or more of the e-commerce stores under at least the Seller Aliases identified on Schedule A and/or other seller aliases not yet known to Plaintiff. On information and belief, Defendants reside and/or operate in the People’s Republic of China or other foreign jurisdictions with lax intellectual property enforcement systems, or redistribute products from the same or

similar sources in those locations. Defendants have the capacity to be sued pursuant to Federal Rule of Civil Procedure 17(b).

10. On information and belief, Defendants either individually or jointly, operate one or more e-commerce stores under the Seller Aliases listed in Schedule A attached hereto. Tactics used by Defendants to conceal their identities and the full scope of their operation make it virtually impossible for Plaintiff to learn Defendants' true identities and the exact interworking of their network. If Defendants provide additional credible information regarding their identities, Plaintiff will take appropriate steps to amend the Complaint.

IV. DEFENDANTS' UNLAWFUL CONDUCT

11. In recent years, Plaintiff has identified numerous fully interactive, e-commerce stores, including those operating under the Seller Aliases, which were offering for sale and/or selling Infringing Products to consumers in this Judicial District and throughout the United States. According to U.S. Customs and Border Protection (CBP), most infringing products now come through international mail and express courier services (as opposed to containers) due to increased sales from offshore online infringers. *The Counterfeit Silk Road: Impact of Counterfeit Consumer Products Smuggled Into the United States*, prepared for The Buy Safe America Coalition by John Dunham & Associates (**Exhibit 3**). The bulk of infringing products sent to the United States "come from China and its dependent territories," accounting for over 90.6% of all cargo with intellectual property rights (IPR) violations. *Id.* Of the \$1.23 billion in total IPR violations intercepted, \$1.12 billion was from China. *Id.* Legislation was previously introduced in the U.S. Senate that would have allowed CBP to seize articles that infringe design patents, thus closing a loophole exploited by infringers.² However, no such law has been enacted.

² See Press Release, U.S. Senator Thom Tillis, *Tillis, Coons, Cassidy & Hirono Introduce Bipartisan Legislation to Seize Counterfeit Products and Protect American Consumers and Businesses* (Dec. 5,

Infringing and pirated products account for billions in economic losses, resulting in tens of thousands of lost jobs for legitimate businesses and broader economic losses, including lost tax revenue. *Id.*

12. Third party service providers like those used by Defendants do not adequately subject new sellers to verification and confirmation of their identities, allowing infringers to “routinely use false or inaccurate names and addresses when registering with these e-commerce platforms.” **Exhibit 4**, Daniel C.K. Chow, *Alibaba, Amazon, and Counterfeiting in the Age of the Internet*, 40 NW. J. INT’L L. & BUS. 157, 186 (2020); *see also*, report on “Combating Trafficking in Counterfeit and Pirated Goods” prepared by the U.S. Department of Homeland Security’s Office of Strategy, Policy, and Plans (Jan. 24, 2020), attached as **Exhibit 5** and finding that on “at least some e-commerce platforms, little identifying information is necessary for [an infringer] to begin selling” and recommending that “[s]ignificantly enhanced vetting of third-party sellers” is necessary. Infringers hedge against the risk of being caught and having their websites taken down from an e-commerce platform by preemptively establishing multiple virtual store-fronts. **Exhibit 5** at p. 22. Since platforms generally do not require a seller on a third-party marketplace to identify the underlying business entity, infringers can have many different profiles that can appear unrelated even though they are commonly owned and operated. **Exhibit 5** at p. 39. Further, “E-commerce platforms create bureaucratic or technical hurdles in helping brand owners to locate or identify sources of [infringement].” **Exhibit 4** at 186-187.

13. Defendants have targeted sales to Illinois residents by setting up and operating e-commerce stores that target United States consumers using one or more Seller Aliases, offer

2019), <https://www.tillis.senate.gov/2019/12/tillis-coons-cassidy-hirono-introduce-bipartisan-legislation-to-seize-counterfeit-products-and-protect-american-consumers-and-businesses>.

shipping to the United States, including Illinois, accept payment in U.S. dollars and, on information and belief, have sold Infringing Products to residents of Illinois.

14. Defendants concurrently employ and benefit from substantially similar advertising and marketing strategies. For example, Defendants facilitate sales by designing e-commerce stores operating under the Seller Aliases so that they appear to unknowing consumers to be authorized online retailers, outlet stores, or wholesalers. E-commerce stores operating under the Seller Aliases appear sophisticated and accept payment in U.S. dollars via credit cards, Alipay, Amazon Pay, and/or PayPal. E-commerce stores operating under the Seller Aliases often include content and images that make it very difficult for consumers to distinguish such stores from an authorized retailer. Plaintiff has not licensed or authorized Defendants to use the GS Design, and none of the Defendants are authorized retailers of genuine GS Products.

15. E-commerce store operators like Defendants commonly engage in fraudulent conduct when registering the Seller Aliases by providing false, misleading, and/or incomplete information to e-commerce platforms to prevent discovery of their true identities and the scope of their e-commerce operation.

16. E-commerce store operators like Defendants regularly register or acquire new seller aliases for the purpose of offering for sale and selling Infringing Products. Such seller alias registration patterns are one of many common tactics used by e-commerce store operators like Defendants to conceal their identities and the full scope and interworking of their operation, and to avoid being shut down.

17. Even though Defendants operate under multiple fictitious aliases, the e-commerce stores operating under the Seller Aliases often share unique identifiers, such as templates with common design elements that intentionally omit any contact information or other information for

identifying Defendants or other Seller Aliases they operate or use. E-commerce stores operating under the Seller Aliases include other notable common features, such as use of the same registration patterns, accepted payment methods, check-out methods, keywords, advertising tactics, similarities in price and quantities, the same incorrect grammar and misspellings, and/or the use of the same text and images. Additionally, Infringing Products for sale by the Seller Aliases bear similar irregularities and indicia of being unauthorized to one another, suggesting that the Infringing Products were manufactured by and come from a common source and that Defendants are interrelated.

18. E-commerce store operators like Defendants are in constant communication with each other and regularly participate in QQ.com chat rooms and through websites such as sellerdefense.cn, kaidianyo.com and kuajingvs.com regarding tactics for operating multiple accounts, evading detection, pending litigation, and potential new lawsuits.

19. Infringers such as Defendants typically operate under multiple seller aliases and payment accounts so that they can continue operation in spite of Plaintiff's enforcement. E-commerce store operators like Defendants maintain offshore bank accounts and regularly move funds from their financial accounts to offshore accounts outside the jurisdiction of this Court to avoid payment of any monetary judgment awarded to Plaintiff. Indeed, analysis of financial account transaction logs from previous similar cases indicates that offshore infringers regularly move funds from U.S.-based financial accounts to offshore accounts outside the jurisdiction of this Court.

20. Defendants are working in active concert to knowingly and willfully manufacture, import, distribute, offer for sale, and sell Infringing Products in the same transaction, occurrence, or series of transactions or occurrences. Defendants, without any authorization or license from

Plaintiff, have jointly and severally, knowingly and willfully offered for sale, sold, and/or imported into the United States for subsequent resale or use the same product that infringes directly and/or indirectly the GS Design. Each e-commerce store operating under the Seller Aliases offers shipping to the United States, including Illinois, and, on information and belief, each Defendant has sold Infringing Products into the United States and Illinois over the Internet.

21. Defendants' infringement of the GS Design in the making, using, offering for sale, selling, and/or importing into the United States for subsequent sale or use of the Infringing Products was willful.

22. Defendants' infringement of the GS Design in connection with the making, using, offering for sale, selling, and/or importing into the United States for subsequent sale or use of the Infringing Products, including the making, using, offering for sale, selling, and/or importing into the United States for subsequent sale or use of Infringing Products into Illinois, is irreparably harming Plaintiff.

COUNT I
INFRINGEMENT OF UNITED STATES DESIGN PATENT NO. D943,817
(35 U.S.C. § 271)

23. Plaintiff hereby re-alleges and incorporates by reference the allegations set forth in the preceding paragraphs.

24. Defendants are making, using, offering for sale, selling, and/or importing into the United States for subsequent sale or use Infringing Products that infringe directly and/or indirectly the ornamental design claimed in the GS Design.

25. Defendants have infringed the GS Design through the aforesaid acts and will continue to do so unless enjoined by this Court. Defendants' wrongful conduct has caused Plaintiff to suffer irreparable harm resulting from the loss of its lawful patent rights to exclude

others from making, using, selling, offering for sale, and importing the patented invention. Plaintiff is entitled to injunctive relief pursuant to 35 U.S.C. § 283.

26. Plaintiff is entitled to recover damages adequate to compensate for the infringement, including Defendants' profits pursuant to 35 U.S.C. § 289. Plaintiff is entitled to recover any other damages as appropriate pursuant to 35 U.S.C. § 284.

PRAYER FOR RELIEF

WHEREFORE, Plaintiff prays for judgment against Defendants as follows:

- 1) That Defendants, their affiliates, officers, agents, servants, employees, attorneys, confederates, and all persons acting for, with, by, through, under or in active concert with them be temporarily, preliminarily, and permanently enjoined and restrained from:
 - a. making, using, offering for sale, selling, and/or importing into the United States for subsequent sale or use any products not authorized by Plaintiff and that include any reproduction, copy or colorable imitation of the design claimed in the GS Design;
 - b. aiding, abetting, contributing to, or otherwise assisting anyone in infringing upon the GS Design; and
 - c. effecting assignments or transfers, forming new entities or associations or utilizing any other device for the purpose of circumventing or otherwise avoiding the prohibitions set forth in Subparagraphs (a) and (b).
- 2) Entry of an Order that, upon Plaintiff's request, those with notice of the injunction, including, without limitation, any online marketplace platforms such as eBay, AliExpress, Alibaba, Amazon, Wish.com, Walmart, and DHgate (collectively, the "Third Party Providers") shall disable and cease displaying any advertisements used by or associated with Defendants in

connection with the sale of goods that infringe the ornamental design claimed in the GS Design;

- 3) That Plaintiff be awarded such damages as it shall prove at trial against Defendants that are adequate to compensate Plaintiff for Defendants' infringement of the GS Design, but in no event less than a reasonable royalty for the use made of the invention by the Defendants, together with interest and costs, pursuant to 35 U.S.C. § 284;
- 4) That the amount of damages awarded to Plaintiff to compensate Plaintiff for infringement of the GS Design be increased by three times the amount thereof, as provided by 35 U.S.C. § 284;
- 5) In the alternative, that Plaintiff be awarded all profits realized by Defendants from Defendants' infringement of the GS Design, pursuant to 35 U.S.C. § 289;
- 6) That Plaintiff be awarded its reasonable attorneys' fees and costs; and
- 7) Award any and all other relief that this Court deems just and proper.

Dated this 26th day of May 2022.

Respectfully submitted,

/s/ Justin R. Gaudio

Amy Ziegler
Justin R. Gaudio
Isaku M. Begert
Justin T. Joseph
Greer, Burns & Crain, Ltd.
300 South Wacker Drive, Suite 2500
Chicago, Illinois 60606
312.360.0080
312.360.9315 (facsimile)
aziegler@gbc.law
jgaudio@gbc.law
ibegert@gbc.law
jjoseph@gbc.law

Counsel for Plaintiff GS Holistic, LLC