

**IN THE UNITED STATES DISTRICT COURT
FOR THE NORTHERN DISTRICT OF ILLINOIS
EASTERN DIVISION**

FCA US LLC,

Plaintiff,

v.

THE PARTNERSHIPS and
UNINCORPORATED ASSOCIATIONS
IDENTIFIED ON SCHEDULE “A,”

Defendants.

Case No. 23-cv-03308

COMPLAINT

Plaintiff FCA US LLC (“FCA” or “Plaintiff”) hereby brings the present action against the Partnerships and Unincorporated Associations identified on Schedule A attached hereto (collectively, the “Defendants”) and alleges as follows:

I. JURISDICTION AND VENUE

1. This Court has original subject matter jurisdiction over the claims in this action pursuant to the provisions of the Lanham Act, 15 U.S.C. § 1051, *et seq.*, 28 U.S.C. § 1338(a)-(b), and 28 U.S.C. § 1331.

2. Venue is proper in this Court pursuant to 28 U.S.C. § 1391, and this Court may properly exercise personal jurisdiction over Defendants since each of the Defendants directly targets business activities toward consumers in the United States, including Illinois, through at least the fully interactive e-commerce stores¹ operating under the seller aliases identified in Schedule A attached hereto (the “Seller Aliases”). Specifically, Defendants have targeted sales to Illinois residents by setting up and operating e-commerce stores that target United States

¹ The e-commerce store URLs are listed on Schedule A hereto under the Online Marketplaces.

consumers using one or more Seller Aliases, offer shipping to the United States, including Illinois, accept payment in U.S. dollars and/or funds from U.S. bank accounts, and, on information and belief, have sold products using infringing and counterfeit versions of Plaintiff's federally registered trademarks to residents of Illinois. Each of the Defendants is committing tortious acts in Illinois, is engaging in interstate commerce, and has wrongfully caused Plaintiff substantial injury in the State of Illinois.

II. INTRODUCTION

3. This action has been filed by Plaintiff to combat e-commerce store operators who trade upon Plaintiff's reputation and goodwill by offering for sale and/or selling unauthorized and unlicensed products, namely automotive accessories, using infringing and counterfeit versions of Plaintiff's federally registered FCA trademarks (the "Counterfeit Products"). Defendants create e-commerce stores operating under one or more Seller Aliases that are advertising, offering for sale, and selling Counterfeit Products to unknowing consumers. E-commerce stores operating under the Seller Aliases share unique identifiers establishing a logical relationship between them and that Defendants' counterfeiting operation arises out of the same transaction, occurrence, or series of transactions or occurrences. Defendants attempt to avoid and mitigate liability by operating under one or more Seller Aliases to conceal both their identities and the full scope and interworking of their counterfeiting operation. Plaintiff is forced to file this action to combat Defendants' counterfeiting of its registered FCA trademarks, as well as to protect unknowing consumers from purchasing Counterfeit Products over the Internet. Plaintiff has been and continues to be irreparably damaged through consumer confusion, dilution, and tarnishment of its valuable FCA trademarks as a result of Defendants' actions and seeks injunctive and monetary relief.

III. THE PARTIES



4. In January of 2021, Peugeot S.A. merged with and into Fiat Chrysler Automobiles N.V., with Fiat Chrysler Automobiles N.V., as the surviving company in the merger. The combined company was renamed Stellantis N.V. (“Stellantis”). FCA US LLC is a wholly owned indirect subsidiary of Stellantis. FCA US LLC and Stellantis are referred to herein together or individually as “FCA.”

5. FCA is a multinational automotive manufacturing corporation and is one of the largest automakers in the world, with millions of vehicles sold in the United States and globally, resulting in billions of dollars in revenue.





6. FCA is associated with some of the most famous brands in the automotive industry, including Chrysler, Dodge, Fiat, Jeep, Lancia, Maserati, Opel, Peugeot, Ram, Vauxhall, Alfa Romeo, and Citroen.





7. Propelled by its reputation and recognizable trademarks, which are carefully curated and monitored, consumers recognize Plaintiff and the FCA brands as a source of reliable and quality vehicles, vehicle parts, and accessories (collectively, the “FCA Products”). FCA has registered many of its trademarks with the United States Patent and Trademark Office. FCA Products typically include at least one of FCA’s registered trademarks. FCA uses its trademarks in connection with the marketing of its FCA Products, including the following marks which are collectively referred to as the “FCA Trademarks.”



| Registration Number | Trademark | Goods and Services |
|----------------------------|------------------|---|
| 570186 | CHRYSLER | For: Automobiles and their structural parts in class 12 |
| 1193586 | PLYMOUTH | For: Structural parts for trucks and vans in class 12 |



| | | |
|---------|---|--|
| 2224038 | PROWLER | For: Structural parts for automobiles in class 12 |
| 3009274 | PT CRUISER | For: Toys, namely, model replicas of land vehicles in class 28 |
| 2861480 | 300C | For: Motor vehicles, namely, automobiles and their structural parts in class 12 |
| 2867905 | 300 HEMI C | For: Structural parts for motor vehicles, namely, automobiles in class 12 |
| 2698729 | CROSSFIRE | For: Toy car, namely, model replicas of an actual "concept" car featuring advanced design and technology in class 28 |
| 3941344 |  | For: Passenger motor vehicles, namely, automobiles and vans, and structural parts and badges therefore in class 12 |
| 1906450 |  | For: structural parts for automobiles and trucks in class 12 |
| 801717 |  | For: Motor vehicles such as automobiles, trucks, and the like, and their structural parts in classes 7, 12, 22, 27 |

| | | |
|---------|------------|--|
| 1189233 | DODGE | For: Trucks and Structural Parts Therefore in class 12 |
| 3538635 | CHALLENGER | For: Automobiles and structural parts therefor in class 12 |
| 2985653 | CHARGER | For: Motor vehicles, namely automobiles and structural parts therefor in class 12 |
| 2196298 | DURANGO | For: motor vehicles, namely, sport utility vehicles and structural parts therefor in class 12 |
| 1800654 | VIPER | For: automobiles and structural parts therefor in class 12 |
| 4325240 | DART | For: Motor vehicles, namely, passenger automobiles, their structural parts, trim and badges in class 12 |
| 3184323 | DAYTONA | For: Motor vehicles, namely, passenger cars, and structural parts therefor in class 12 |
| 4651340 | NITRO | For: Badges for vehicles in class 12 |
| 5795360 | REDEYE | For: Motor vehicles, namely, passenger automobiles; Automobile engines incorporated as an integral part of a motor vehicle in class 12 |
| 5839879 | SCAT PACK | For: Motor vehicles, namely, passenger automobiles, their structural parts, trim and badges in class 12 |
| 3264572 | SUPER BEE | For: Badge for vehicles in class 12 |
| 3098722 | SRT | For: Motor vehicles, namely, passenger cars, and |

| | | |
|---------|---|--|
| | | structural parts and engines therefor in class 12 |
| 3098724 | SRT-10 | For: Structural parts for motor vehicles, namely, passenger cars and trucks in class 12 |
| 3193249 | SRT8 | For: Motor vehicles, namely, passenger cars, sport utility vehicles, and structural parts and engines therefor in class 12 |
| 3032735 | DODGE SUPER 8 HEMI | For: TOYS, NAMELY, MODEL REPLICAS OF LAND VEHICLES in class 28 |
| 3209150 | R/T | For: Land vehicles in class 12 |
| 1762717 |  | For: Automobiles structural parts in class 12 |
| 2475380 |  | For: automobiles and their structural parts in class 12 |
| 5382205 |  | For: Motor vehicles, namely, passenger automobiles and trim and badges therefor, excluding tires in class 12 |
| 5382204 |  | For: Motor vehicles, namely, passenger automobiles, their structural parts, trim and badges in class 12 |

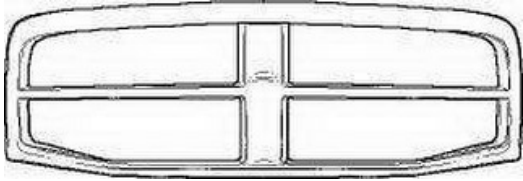
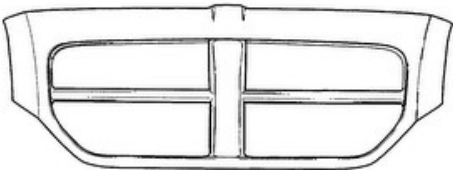
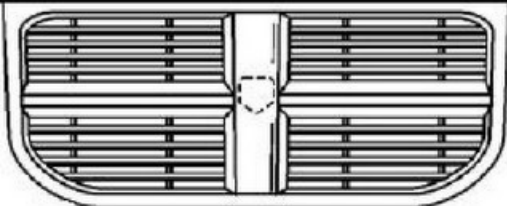

| | | |
|----------------|---|--|
| <p>5627792</p> |  | <p>For: Automobile engines in class 12</p> |
| <p>4752987</p> |  | <p>For: Automobile engines in class 12</p> |
| <p>4831385</p> |  | <p>For: Motor vehicles, namely, passenger automobiles, their structural parts, trim and badges in class 12</p> |
| <p>4696903</p> |  | <p>For: Badges for vehicles in class 12</p> <p>For: T-shirts in class 25</p> |
| <p>3264573</p> |  | <p>For: Badge for vehicles in class 12</p> |



| | | |
|----------------|---|---|
| <p>2760226</p> |  | <p>For: Structural parts for automobiles in class 12</p> |
| <p>4365092</p> |  | <p>For: Structural parts, trim and badges for motor vehicles, namely, passenger automobiles in class 12</p> |
| <p>1870470</p> |  | <p>For: Structural parts for automobiles in class 12</p> |
| <p>2994818</p> |  | <p>For: Structural parts for automobiles, namely, sport utility vehicles in class 12</p> |
| <p>3053379</p> |  | <p>For: Motor vehicles, namely passenger cars, and their structural parts in class 12</p> |
| <p>3341561</p> |  | <p>For: Structural parts for motor vehicles, namely, sport utility vehicles in class 12</p> |

| | | |
|---------|---|--|
| 1741153 | HEMI | For: automotive vehicles; namely, automobiles and/or trucks, and engines for automobiles and/or trucks in class 12 |
| 3018766 | HEMI | For: Toys, namely, figurines in class 28 |
| 383304 |  | For: Vehicle Body Sun Visors, Grille Covers and Screens, Seat Covers, Arm Rests, Running Board Moldings, Vehicle Rear View Mirrors, Stone Deflectors, Steering Wheels, Wheel Discs, Wheel Shields, Windshield Wipers, Windshield Wiper Blades, Spare Tire Valve Extensions, Bumper Guards, License Trim Frame, Brakes and Parts Thereof Vehicle Axle Assemblies, Vehicle Axle Housings, and Steering Apparatus and Parts Thereof, Including Tie Rods and Drag Links in classes 7, 12, 22, 27 |
| 2919922 |  | <p>For: Antifreeze; leak sealants for automobile brake systems, cooling systems, and power steering systems; automobile gasket cement; and automotive hydraulic fluids in class 1</p> <p>For: Vehicle corrosion inhibiting preparations in class 2</p> <p>For: Wax, paste and liquid preparations for cleaning, polishing and preserving painted, varnished, or finished metallic surfaces; fabric cleaners, glass cleaners, and</p> |

| | | |
|--|--|---|
| | | <p>automobile top preservation preparations in class 3</p> <p>For: Automotive lubricants and motor and fuel oils in class 4</p> <p>For: Crankshafts, crankshaft bearings, and crankshaft connecting rods for internal combustion engines; land vehicle parts, namely, air cleaners, oil and fuel filters, engine mufflers, exhaust pipes, engine roller and ball bearings, carburetors, fuel injectors, fuel pumps, vehicle radiator connecting hoses, gaskets for internal combustion engines, mechanical seals, piston rings and engine rods in class 7</p> <p>For: Automotive fuel and oil gauges, batteries for motor vehicles in class 9</p> <p>For: Motor vehicle engines; land vehicle parts, namely, differential gears and pinions, axle housings and axle assemblies, universal joints, drive gears, windshield visors, grilles, seat covers, arm rests, running board moldings, rear view mirrors, stone deflectors, steering wheels, windshield wipers and blades, spare tire valve extensions, bumper guards, license plate frames; brakes for land vehicles and brake parts, namely, linings, drums and shoes; drive belts and transmission belts in class 12</p> |
|--|--|---|

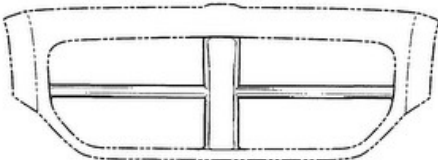

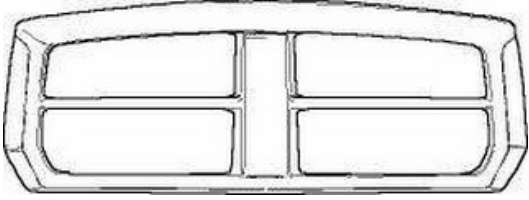
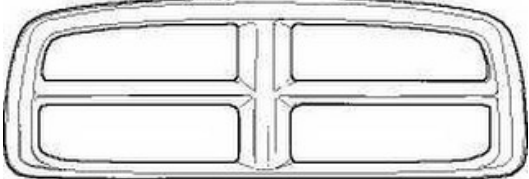



| | | |
|---------|--|---|
| | | <p>For: Retail automobile parts and accessories stores; automobile dealerships in class 35</p> <p>For: Automobile body cleaning, repair and finishing services for others; automobile repair and maintenance services; and installation and repair of motor vehicle tires in class 37</p> <p>For: Entertainment services in the nature of automobile racing in class 41</p> |
| 3208928 |  | For: Structural parts of motor vehicle engines in class 12 |
| 3806969 | RAM | For: Motor vehicles, namely, passenger automobiles, their structural parts, trim and badges in class 12 |
| 3071692 | BIG HORN | For: Motor vehicles, namely, pickup trucks and structural parts therefor in class 12 |
| 1973148 | LARAMIE | For: Motor vehicles and structural parts therefor in class 12 |
| 6044059 | LONGHORN | For: Passenger automobiles, namely, pickup trucks and structural parts therefor in class 12 |
| 3303302 | RAMCHARGER | For: Motor vehicles, namely, pick-up trucks in class 12 |

| | | |
|---------|---|---|
| 4946811 | REBEL | For: Passenger automobiles, namely, trucks and structural parts therefor in class 12 |
| 6289815 | TRX | For: Motor vehicles, namely, trucks, excluding all terrain vehicles; and structural parts for motor vehicles, excluding tires in class 12 |
| 4084999 | TRADESMAN | For: Motor vehicles, namely, passenger automobiles, their structural parts, trim and badges in class 12 |
| 2979165 | RUMBLE BEE | For: Structural parts for pickup trucks in class 12 |
| 2999082 |  | For: Trucks, vans and structural parts therefor in class 12 |
| 3030313 |  | For: Structural parts for motor vehicles in class 12 |
| 3062290 |  | For: Motor vehicles, namely passenger cars, pickup trucks, minivans, vans, and sport utility vehicles, and their structural parts in class 12 |

| | | |
|---------|---|--|
| 3160030 |  | For: Motor vehicles, namely pickup trucks, and their structural parts in class 12 |
| 2970629 |  | For: Motor vehicles, namely pickup trucks, and their structural parts in class 12 |
| 2593670 |  | For: Trucks and their structural parts in class 12 |
| 0526175 | JEEP | For: Automobiles and structural parts thereof in class 12 |
| 1130015 | JEEP | For: Clothing-namely, jackets, rain wear, head wear, t-shirts, sweaters, coats, gloves in class 25 |
| 1134153 | JEEP | For: Glassware in class 21 |
| 1236540 | JEEP | For: Toys-Namely, Model Replicas of Land Vehicles in class 28 |
| 2512866 | JEEP | For: Household containers, namely, mugs and insulated containers for beverages in class 21 |
| 2849309 | JEEP | For: Footwear, namely, boots in class 25 |
| 4091155 | JEEP | For: Backpacks; Luggage in class 18 |
| 1557843 | WRANGLER | For: Automobiles in class 12 |
| 4518178 | CHEROKEE | For: Motor vehicles, namely, passenger automobiles, their |

| | | |
|---------|-----------------------|--|
| | | structural parts, trim and badges in class 12 |
| 2704632 | GRAND CHEROKEE | For: Sport utility vehicles in class 12 |
| 4441441 | GRAND CHEROKEE SUMMIT | For: Motor vehicles, namely, passenger automobiles, their structural parts, trim and badges in class 12 |
| 751966 | WAGONEER | For: Passenger Automotive Vehicles Including Station Wagons in class 12 |
| 3096252 | COMPASS | For: Motor vehicles, namely, automobiles and structural parts thereof in class 12 |
| 4057454 | COMPASS LATITUDE | For: Motor vehicles, namely, passenger automobiles, their structural parts, trim and badges in class 12 |
| 3592942 | GLADIATOR | For: Motor vehicles, namely passenger sport utility concept vehicles and structural parts therefor in class 12 |
| 3013733 | COMMANDER | For: Motor vehicles, namely, sport utility vehicles, and structural parts and engines therefor in class 12 |
| 6142256 | DESERT RATED | For: Motor vehicles, namely, sport utility vehicles, their structural parts, trim and badges in class 12 |
| 5573761 | DESERTHAWK | For: Motor vehicles, namely, passenger automobiles, their structural parts, trim and badges in class 12 |
| 3304375 | FREEDOM TOP | For: Removable modular roof sold as an integral component of sport utility vehicles in class 12 |

| | | |
|---------|---|---|
| 5492469 | GOLDEN EAGLE | For: Motor vehicles, namely, passenger automobiles, their structural parts, trim and badges in class 12 |
| 4060519 | MOJAVE | For: Motor vehicles, namely, passenger vehicles, their structural parts, trim and badges in class 12 |
| 2841486 | PATRIOT | For: Motor vehicles, namely, automobiles and structural parts sold exclusively through authorized dealerships to its retail customers and excluding buses in class 12 |
| 1415771 | RENEGADE | For: Passenger utility land vehicles in class 12 |
| 3387789 | WILLYS | For: Automobiles in class 12 |
| 2700419 | IT'S A JEEP THING... YOU WOULDN'T UNDERSTAND | For: Bumper stickers and windshield decals in class 16 |
| 5633062 | JEEP SPIRIT | For: T-shirts in class 25 |
| 6026393 | AMERICAN MOTORS | For: Badges for vehicles in class 12 |
| 5380960 | BACKCOUNTRY | For: Motor vehicles, namely, passenger automobiles, their structural parts, trim and badges, but not including tires for passenger automobiles in class 12 |
| 3453260 | GO ANYWHERE DO ANYTHING | For: Motor vehicles in class 12 |
| 3157861 |  | For: Badges for automobiles in class 12 |

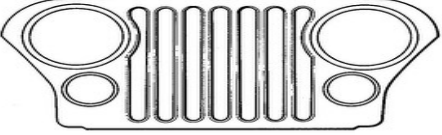
| | | |
|---------|---|---|
| 4272873 |  | For: Motor vehicles, namely, passenger automobiles, their structural parts, trim and badges in class 12 |
| 5291829 |  | For: Motor vehicles, namely, passenger automobiles, their structural parts, trim and badges in class 12 |
| 3346795 |  | For: Structural parts for automobiles in class 12 |
| 3918898 |  | For: Die-cast scale model replicas of vehicles in class 28 |
| 4891473 |  | For: Automobiles and structural parts therefor; Badges for vehicles in class 12 |
| 4441442 |  | For: Structural parts, trim and badges for motor vehicles, namely, passenger automobiles in class 12 |
| 3276658 |  | For: T-shirts in class 25 |
| 1170088 |  | For: Land Vehicles in class 12 |

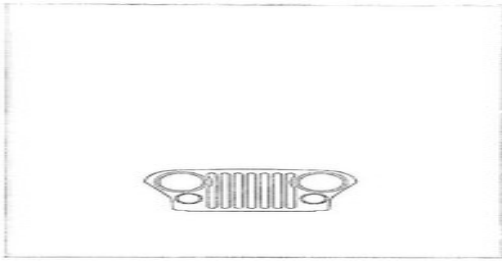
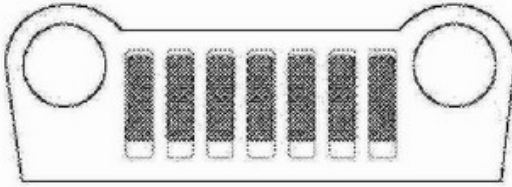
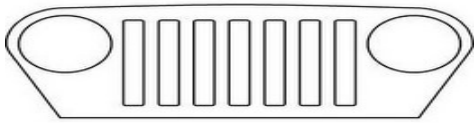
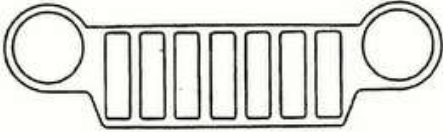
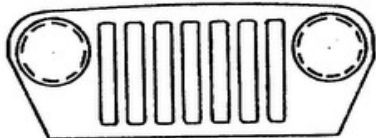
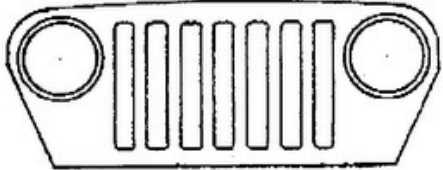
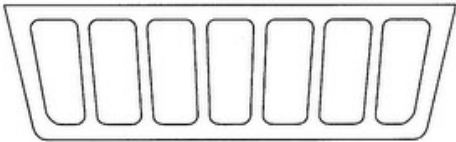
| | | |
|---------|---|--|
| 2862487 |  | For: Parts for motor vehicles, namely, grilles and grille fascias in class 12 |
| 3199299 |  | For: Motor vehicles, namely automobiles, and structural parts therefor in class 12 |
| 4043984 |  | For: Parts for motor vehicles, namely, windshields in class 12 |
| 2924936 |  | For: Structural parts for motor vehicles, namely, automobiles and sport utility vehicles in class 12 |
| 2161779 |  | For: sport utility vehicles in class 12 |
| 2794553 |  | For: Motor vehicle parts, namely, grilles and grille appliques in class 12 |
| 2764249 |  | For: Structural parts for motor vehicles, namely, automobiles and sport utility vehicles in class 12 |

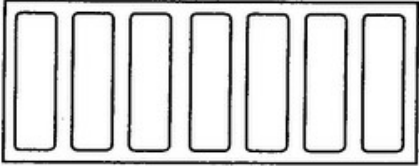
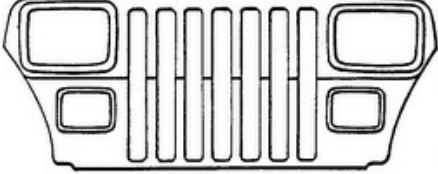
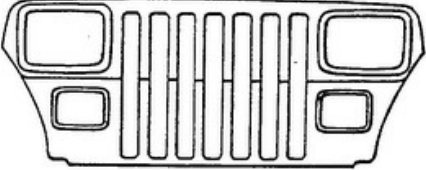
| | | |
|---------|---|---|
| 2823099 |  | For: Parts for motor vehicles, namely grilles and grille appliques in class 12 |
| 1433760 |  | For: Utility land vehicles in class 12 |
| 2732021 |  | For: Parts for motor vehicles, namely, grilles and grille appliques in class 12 |

8. The above U.S. registrations for the FCA Trademarks are valid, subsisting, in full force and effect, and many are incontestable pursuant to 15 U.S.C. § 1065. The registrations for the FCA Trademarks constitute *prima facie* evidence of their validity and of FCA’s exclusive right to use the FCA Trademarks pursuant to 15 U.S.C. § 1057(b). True and correct copies of the United States Registration Certificates for the above-listed FCA Trademarks are attached hereto as **Exhibit 1**.

9. The FCA Trademarks are distinctive when applied to the FCA Products, signifying to the purchaser that the products come from FCA and are manufactured to FCA’s quality standards. Whether FCA manufactures the products itself or contracts with others to do so, FCA has ensured that products bearing the FCA Trademarks are manufactured to the highest quality standards.

10. The FCA Trademarks are famous marks, as that term is used in 15 U.S.C. § 1125(c)(1), and have been used by FCA for many years. The innovative marketing and product designs of the FCA Products have enabled the FCA brands to achieve widespread recognition and fame and have made the FCA Trademarks some of the most well-known marks in the automotive industry. The widespread fame, outstanding reputation, and significant goodwill associated with the FCA brands have made the FCA Trademarks valuable assets of FCA.

11. FCA has expended substantial time, money, and other resources in developing, advertising, and otherwise promoting the FCA Trademarks. In fact, FCA has expended millions of dollars annually in advertising, promoting, and marketing featuring the FCA Trademarks. FCA Products have also been the subject of extensive unsolicited publicity resulting from their high quality, performance, and innovative design. As a result, products bearing the FCA Trademarks are widely recognized and exclusively associated by consumers, the public, and the trade as being high-quality products sourced from FCA. FCA Products have become among the most popular of their kind in the U.S. and the world. The FCA Trademarks have achieved tremendous fame and recognition which has only added to the distinctiveness of the marks. As such, the goodwill associated with the FCA Trademarks is of incalculable and inestimable value to FCA.

12. FCA Products are sold to consumers through authorized dealerships, including several in the Chicago area. FCA has a website at [stellantis.com](https://www.stellantis.com) which allows customers to search the FCA brands and find official websites for the associated brands. The [stellantis.com](https://www.stellantis.com) website features proprietary content, images, and designs exclusive to FCA.

The Defendants

13. Defendants are individuals and business entities of unknown makeup who own and/or operate one or more of the e-commerce stores under at least the Seller Aliases identified on

Schedule A and/or other seller aliases not yet known to Plaintiff. On information and belief, Defendants reside and/or operate in the People's Republic of China or other foreign jurisdictions, or redistribute products from the same or similar sources in those locations. Defendants have the capacity to be sued pursuant to Federal Rule of Civil Procedure 17(b).

14. On information and belief, Defendants, either individually or jointly, operate one or more e-commerce stores under the Seller Aliases listed in Schedule A attached hereto. Tactics used by Defendants to conceal their identities and the full scope of their operations make it virtually impossible for Plaintiff to learn Defendants' true identities and the exact interworking of their counterfeit network. If Defendants provide additional credible information regarding their identities, Plaintiff will take appropriate steps to amend the Complaint.

IV. DEFENDANTS' UNLAWFUL CONDUCT

15. The success of the FCA brands has resulted in significant counterfeiting of the FCA Trademarks. Consequently, FCA has a worldwide anti-counterfeiting program and regularly investigates suspicious e-commerce stores identified in proactive Internet sweeps and reported by consumers. In recent years, FCA has identified numerous fully interactive, e-commerce stores offering Counterfeit Products on online marketplace platforms such as Amazon, eBay, AliExpress, Alibaba, Wish.com, Walmart, Etsy, and DHgate, including the e-commerce stores operating under the Seller Aliases. The Seller Aliases target consumers in this Judicial District and throughout the United States. According to a U.S. Customs and Border Protection (CBP) report, in 2021, CBP made over 27,000 seizures of goods with intellectual property rights (IPR) violations totaling over \$3.3 billion, an increase of \$2.0 billion from 2020. *Intellectual Property Rights Seizure Statistics, Fiscal Year 2021*, U.S. Customs and Border Protection (**Exhibit 2**). Of the 27,000 in total IPR

seizures, over 24,000 came through international mail and express courier services (as opposed to containers), most of which originated from China and Hong. *Id.*

16. Third party service providers like those used by Defendants do not adequately subject new sellers to verification and confirmation of their identities, allowing counterfeiters to “routinely use false or inaccurate names and addresses when registering with these e-commerce platforms.” **Exhibit 3**, Daniel C.K. Chow, *Alibaba, Amazon, and Counterfeiting in the Age of the Internet*, 40 NW. J. INT’L L. & BUS. 157, 186 (2020); *see also*, report on “Combating Trafficking in Counterfeit and Pirated Goods” prepared by the U.S. Department of Homeland Security’s Office of Strategy, Policy, and Plans (Jan. 24, 2020) attached as **Exhibit 4** and finding that on “at least some e-commerce platforms, little identifying information is necessary for a counterfeiter to begin selling” and recommending that “[s]ignificantly enhanced vetting of third-party sellers” is necessary. Counterfeiters hedge against the risk of being caught and having their websites taken down from an e-commerce platform by preemptively establishing multiple virtual store-fronts. **Exhibit 4** at 22. Since platforms generally do not require a seller on a third-party marketplace to identify the underlying business entity, counterfeiters can have many different profiles that can appear unrelated even though they are commonly owned and operated. **Exhibit 4** at 39. Further, “E-commerce platforms create bureaucratic or technical hurdles in helping brand owners to locate or identify sources of counterfeits and counterfeiters.” **Exhibit 3** at 186-187.

17. Defendants have targeted sales to Illinois residents by setting up and operating e-commerce stores that target United States consumers using one or more Seller Aliases, offer shipping to the United States, including Illinois, accept payment in U.S. dollars and/or funds from U.S. bank accounts and, on information and belief, have sold Counterfeit Products to residents of Illinois.

18. Defendants concurrently employ and benefit from substantially similar advertising and marketing strategies. For example, Defendants facilitate sales of Counterfeit Products by designing the e-commerce stores operating under the Seller Aliases so that they appear to unknowing consumers to be authorized online retailers, outlet stores, or wholesalers. E-commerce stores operating under the Seller Aliases appear sophisticated and accept payment in U.S. dollars and/or funds from U.S. bank accounts via credit cards, Alipay, Amazon Pay, and/or PayPal. E-commerce stores operating under the Seller Aliases often include content and images that make it difficult for consumers to distinguish such stores from an authorized retailer. On information and belief, FCA has not licensed or authorized Defendants to use any of the FCA Trademarks, and none of the Defendants are authorized retailers of genuine FCA Products.

19. Many Defendants also deceive unknowing consumers by using one or more FCA Trademarks without authorization within the content, text, and/or meta-tags of their e-commerce stores to attract various search engines crawling the Internet looking for websites relevant to consumer searches for FCA Products. Other e-commerce stores operating under Seller Aliases omit using FCA Trademarks in the item title to evade enforcement efforts while using strategic item titles and descriptions that will trigger their listings when consumers are searching for FCA Products.

20. E-commerce store operators like Defendants commonly engage in fraudulent conduct when registering the Seller Aliases by providing false, misleading and/or incomplete information to e-commerce platforms to prevent discovery of their true identities and the scope of their e-commerce operation.

21. E-commerce store operators like Defendants regularly register or acquire new seller aliases for the purpose of offering for sale and selling Counterfeit Products. Such seller alias

registration patterns are one of many common tactics used by e-commerce store operators like Defendants to conceal their identities, the full scope and interworking of their counterfeiting operation, and to avoid being shut down.

22. Even though Defendants operate under multiple fictitious aliases, the e-commerce stores operating under the Seller Aliases often share unique identifiers, such as templates with common design elements that intentionally omit any contact information or other information for identifying Defendants or other Seller Aliases they operate or use. E-commerce stores operating under the Seller Aliases include other notable common features such as use of the same registration patterns, accepted payment methods, check-out methods, keywords, advertising tactics, similarities in price and quantities, the same incorrect grammar and misspellings, and/or the use of the same text and images. Additionally, Counterfeit Products for sale by the Seller Aliases bear similar irregularities and indicia of being counterfeit to one another, suggesting that the Counterfeit Products were manufactured by and come from a common source and that Defendants are interrelated.

23. E-commerce store operators like Defendants are in constant communication with each other and regularly participate in QQ.com chat rooms and through websites such as sellerdefense.cn, kaidianyo.com and kuajingvs.com regarding tactics for operating multiple accounts, evading detection, pending litigation, and potential new lawsuits.

24. Counterfeiters such as Defendants typically operate under multiple seller aliases and payment accounts so that they can continue operation in spite of Plaintiff's enforcement. E-commerce store operators like Defendants maintain off-shore bank accounts and regularly move funds from their financial accounts to off-shore accounts outside the jurisdiction of this Court to avoid payment of any monetary judgment awarded to Plaintiff. Indeed, analysis of financial

account transaction logs from previous similar cases indicates that off-shore counterfeiters regularly move funds from U.S.-based financial accounts to off-shore accounts outside the jurisdiction of this Court.

25. Defendants are working in active concert to knowingly and willfully manufacture, import, distribute, offer for sale, and sell Counterfeit Products in the same transaction, occurrence, or series of transactions or occurrences. Defendants, without any authorization or license from FCA, have jointly and severally, knowingly and willfully used and continue to use the FCA Trademarks in connection with the advertisement, distribution, offering for sale, and sale of Counterfeit Products into the United States and Illinois over the Internet.

26. Defendants' unauthorized use of the FCA Trademarks in connection with the advertising, distribution, offering for sale, and sale of Counterfeit Products, including the sale of Counterfeit Products into the United States, including Illinois, is likely to cause and has caused confusion, mistake, and deception by and among consumers and is irreparably harming Plaintiff.

COUNT I
TRADEMARK INFRINGEMENT AND COUNTERFEITING (15 U.S.C. § 1114)

27. Plaintiff hereby re-alleges and incorporates by reference the allegations set forth in the preceding paragraphs.

28. This is a trademark infringement action against Defendants based on their unauthorized use in commerce of counterfeit imitations of the federally registered FCA Trademarks in connection with the sale, offering for sale, distribution, and/or advertising of infringing goods. The FCA Trademarks are highly distinctive marks. Consumers have come to expect the highest quality from FCA Products sold or marketed under the FCA Trademarks.

29. Defendants have sold, offered to sell, marketed, distributed, and advertised, and are still selling, offering to sell, marketing, distributing, and advertising products using counterfeit reproductions of the FCA Trademarks without FCA's permission.

30. FCA is the exclusive owner of the FCA Trademarks. FCA's United States Registrations for the FCA Trademarks (**Exhibit 1**) are in full force and effect. On information and belief, Defendants have knowledge of FCA's rights in the FCA Trademarks and are willfully infringing and intentionally using counterfeits of the FCA Trademarks. Defendants' willful, intentional, and unauthorized use of the FCA Trademarks is likely to cause and is causing confusion, mistake, and deception as to the origin and quality of the Counterfeit Products among the general public.

31. Defendants' activities constitute willful trademark infringement and counterfeiting under Section 32 of the Lanham Act, 15 U.S.C. § 1114.

32. FCA has no adequate remedy at law and, if Defendants' actions are not enjoined, FCA will continue to suffer irreparable harm to its reputation and the goodwill of its well-known FCA Trademarks.

33. The injuries and damages sustained by Plaintiff have been directly and proximately caused by Defendants' wrongful reproduction, use, advertisement, promotion, offering to sell, and sale of Counterfeit Products.

COUNT II
FALSE DESIGNATION OF ORIGIN (15 U.S.C. § 1125(a))

34. Plaintiff hereby re-alleges and incorporates by reference the allegations set forth in the preceding paragraphs.

35. Defendants' promotion, marketing, offering for sale, and sale of Counterfeit Products has created and is creating a likelihood of confusion, mistake, and deception among the

general public as to the affiliation, connection, or association with FCA or the origin, sponsorship, or approval of Defendants' Counterfeit Products by FCA.

36. By using the FCA Trademarks in connection with the sale of Counterfeit Products, Defendants create a false designation of origin and a misleading representation of fact as to the origin and sponsorship of the Counterfeit Products.

37. Defendants' false designation of origin and misrepresentation of fact as to the origin and/or sponsorship of the Counterfeit Products to the general public involves the use of counterfeit marks and is a willful violation of Section 43 of the Lanham Act, 15 U.S.C. § 1125.

38. There is no adequate remedy at law and, if Defendants' actions are not enjoined, Plaintiff will continue to suffer irreparable harm to its reputation and the associated goodwill of the FCA brand.

PRAYER FOR RELIEF

WHEREFORE, Plaintiff prays for judgment against Defendants as follows:

- 1) That Defendants, their affiliates, officers, agents, servants, employees, attorneys, confederates, and all persons acting for, with, by, through, under or in active concert with them be temporarily, preliminarily and permanently enjoined and restrained from:
 - a. using the FCA Trademarks or any reproductions, counterfeit copies, or colorable imitations thereof in any manner in connection with the distribution, promotion, marketing, advertising, offering for sale, or sale of any product that is not a genuine FCA Product or is not authorized by FCA to be sold in connection with the FCA Trademarks;
 - b. passing off, inducing, or enabling others to sell or pass off any products as genuine FCA Products or any other products produced by FCA that are not FCA's, or not

- produced under the authorization, control, or supervision of FCA and approved by FCA for sale under the FCA Trademarks;
- c. committing any acts calculated to cause consumers to believe that Defendants' Counterfeit Products are those sold under the authorization, control, or supervision of FCA, or are sponsored by, approved by, or otherwise connected with FCA;
 - d. further infringing the FCA Trademarks and damaging FCA's goodwill; and
 - e. manufacturing, shipping, delivering, holding for sale, transferring or otherwise moving, storing, distributing, returning, or otherwise disposing of, in any manner, products or inventory not manufactured by or for FCA, nor authorized by FCA to be sold or offered for sale, and which bear any of FCA's trademarks, including the FCA Trademarks, or any reproductions, counterfeit copies, or colorable imitations thereof;
- 2) Entry of an Order that, upon Plaintiff's request, those with notice of the injunction, including, without limitation, any online marketplace platforms such as eBay, AliExpress, Alibaba, Amazon, Wish.com, Walmart, Etsy, and DHgate (collectively, the "Third Party Providers") shall disable and cease displaying any advertisements used by or associated with Defendants in connection with the sale of counterfeit and infringing goods using the FCA Trademarks;
 - 3) That Defendants account for and pay to Plaintiff all profits realized by Defendants by reason of Defendants' unlawful acts herein alleged, and that the amount of damages for infringement of the FCA Trademarks be increased by a sum not exceeding three times the amount thereof as provided by 15 U.S.C. § 1117;
 - 4) In the alternative, that Plaintiff be awarded statutory damages for willful trademark counterfeiting pursuant to 15 U.S.C. § 1117(c)(2) of \$2,000,000 for each and every use of the FCA Trademarks;

- 5) That Plaintiff be awarded its reasonable attorneys' fees and costs; and
- 6) Award any and all other relief that this Court deems just and proper.

Dated this 25th day of May 2023.

Respectfully submitted,

/s/ Justin R. Gaudio

Amy C. Ziegler

Justin R. Gaudio

Kahlia R. Halpern

Quinn B. Guillermo

Greer, Burns & Crain, Ltd.

300 South Wacker Drive, Suite 2500

Chicago, Illinois 60606

312.360.0080 / 312.360.9315 (facsimile)

aziegler@gbc.law

jgaudio@gbc.law

khalpern@gbc.law

qguillermo@gbc.law

Counsel for Plaintiff FCA US LLC